

LAB EXPERIENCE COURSEWARE

HANDS-ON LABS ALIGNED WITH ACADEMIC
CURRICULUM FOR AUTONOMOUS SYSTEMS

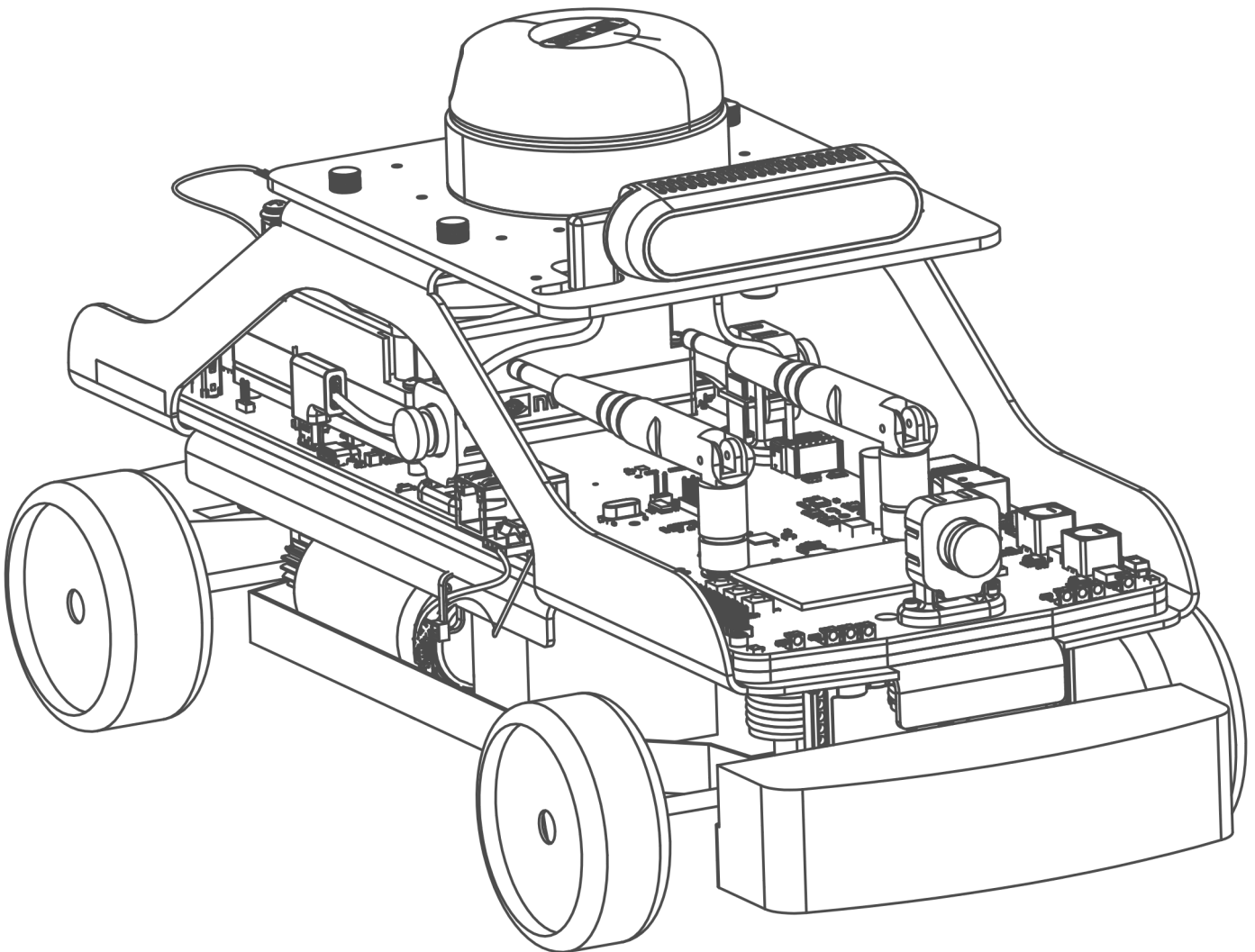

LAB EXPERIENCE COURSEWARE

ACADEMIC RESOURCE GUIDE

	Curriculum Topic	Software/Tools Used
SENSOR INTERFACING	MEMS Sensor Data Acquisition (Accelerometer & Gyroscope)	Python, Qlab, MEMS Sensors
	Visualizing Sensor Data in Real-Time	Python
	Parsing and Interpreting Sensor Data	Python
	Statistical Modeling	Python
	Statistical Analysis of Sensor Data	Python
	Sensor Data Noise Characterization	Python
	Configuring Sensor Data Acquisition Parameters	Python
	Understanding Sensor Noise and Uncertainty	Python
	Z-axis Gyroscope & Accelerometer Data Analysis	Python
	Visualizing Sensor Data Distribution	Python
STATE ESTIMATION	Implementing Kinematic Bicycle Model	Python
	Kalman Filter with Dead Reckoning	Python
	Jacobian Calculation for Motion Model	Python
	Extended Kalman Filter (EKF) for State Estimation	Python
	GPS Measurement Integration in State Estimation	Python, Gyroscope
	Kalman Filter for Heading Estimation (Gyroscope Data)	Python, Gyroscope
	Sensor Fusion: Combining GPS and Gyroscope Data	Python, Gyroscope
	Correction Step in Kalman Filter using GPS Data	Python, Gyroscope
	Prediction Step in Extended Kalman Filter	Python
VEHICLE CONTROL	Implementing Longitudinal Speed Control	Python, Tachometer
	PID Controller Design for Speed	Python, Motor Control
	Tuning Speed Controller Gains (P, I, D)	Python, Tachometer, Motor Control
	Developing Stanley Steering Controller	Python, Steering Mechanism, Tachometer
	Implementing Geometric Lateral Control for Steering	Python, Steering Mechanism, Tachometer
	Waypoint Following and Trajectory Generation	Python, Steering Mechanism
	Integrating Sensor Data for Steering Control	Python, LiDAR, Steering Mechanism
	Stanley vs Pure Pursuit Performance Evaluation	Python, Steering Mechanism
	Lidar Calibration and Sensor Alignment for Obstacle Detection	Python, LiDAR, Steering Mechanism

LAB EXPERIENCE COURSEWARE

ACADEMIC RESOURCE GUIDE

ENVIRONMENT INTERPRETATION

Curriculum Topic	Software/Tools Used
Developing LiDAR Inverse Measurement Model	Python, LiDAR
Creating Polar Occupancy Grid from LiDAR Data	Python, LiDAR
Bilinear Interpolation for Occupancy Grid Mapping	Python, LiDAR
Mapping LiDAR Data to Cartesian Grid	Python, LiDAR
Building and Updating Global Occupancy Grid Map	Python, LiDAR
Integrating LiDAR Scans over Time for Environment Mapping	Python, LiDAR
Occupancy Grid Map Update Using Binary Bayes Filter	Python, LiDAR
Vehicle Trajectory Generation for Environment Exploration	Python, LiDAR

IMAGE INTERPRETATION

Camera Calibration with Chess Board Pattern	Python, OpenCV, CSI camera, Intel RealSense D435 camera
Calculating Camera Intrinsic and Lens Distortion	Python, OpenCV, CSI camera, Intel RealSense D435 camera
Capturing and Analyzing Images for Calibration	Python, OpenCV, CSI camera, Intel RealSense D435 camera
Correcting Image Distortion Using Calibration Data	Python, OpenCV, CSI camera, Intel RealSense D435 camera
Image Filtering for Feature Enhancement	Python, OpenCV, CSI camera, Intel RealSense D435 camera
Line Detection Using Image Processing Techniques	Python, OpenCV, CSI camera, Intel RealSense D435 camera
Line Detection for Lane Following in Self-Driving	Python, OpenCV, CSI camera, Intel RealSense D435 camera
Extracting Lane Markings for Autonomous Driving	Python, OpenCV, CSI camera, Intel RealSense D435 camera